

Solar Thermal Venetian Blind - Development and Evaluation of a Switchable Thermal Coupling

Simon Frederik Haeringer (1), Ikbel Abderrahman (1), Puttakhun Vongsingha (2), Sofia Camarena Covarrubias (1), Ulrich Amann (1), Tilmann E. Kuhn (1), Paul-Rouven Denz (2), Christoph Maurer (1)

(1) Fraunhofer-Institute for Solar Energy Systems ISE

Heidenhofstr. 2, D-79110 Freiburg

Tel.: +49 (0) 761 4588 2020

E-Mail: simon.haeringer@ise.fraunhofer.de

Internet: www.ise.fraunhofer.de

(2) Facade-Lab GmbH

Am Wall 17, D-14979 Grossbeeren/Berlin

Abstract: Solar thermal venetian blinds combine the switchable transparency and glare protection of venetian blinds with the functionality of a solar thermal collector. Additionally the temperature of the glazing cavity in which the blinds are mounted can be decreased. The solar energy that is absorbed by the slats is transferred to the header tube by incorporating heat-pipes into the slats and using a switchable thermal coupling. This makes solar thermal venetian blind technically feasible. While the switchable thermal coupling is closed, the heat is removed because thermal contact exists between the heat-pipe condensator and the header tube. To allow the movement of the slats the coupling can be opened by a mechanism. Design parameters for the development of such a switchable thermal coupling were established. Different mechanisms were compared using evaluation criteria. Furthermore an adapter with the purpose of improving the heat transfer was designed and investigated. Based on the results a first test sample of a solar thermal venetian blind is being manufactured.

Solarthermische Jalousie – Entwicklung und Bewertung einer schaltbaren thermischen Kopplung - Kurzfassung: Solarthermische Jalousien verbinden die schaltbare Transparenz und den Blendschutz einer Jalousie mit den Funktionen eines solarthermischen Kollektors sowie einer verringerten Temperatur des Verglasungszwischenraums, in dem sie montiert werden. Werden Heat-Pipes in den Lamellen verwendet, so kann die in den Lamellen absorbierte Energie über eine schaltbare thermische Kopplung an den Sammelkanal übergeben werden. Dies macht eine technische Umsetzung der solarthermischen Jalousie möglich. Ist die schaltbare thermische Kopplung geschlossen, so besteht thermischer Kontakt zwischen Heat-Pipe-Kondensator und Sammelkanal und die Wärme wird abgeführt. Um das Bewegen der Lamellen zu ermöglichen, wird diese Kopplung mit einem Mechanismus geöffnet. Gestaltungsparameter für die Entwicklung einer solchen schaltbaren thermischen Kopplung wurden aufgestellt und verschiedene Mechanismen mittels Bewertungskriterien verglichen. Außerdem wurde zur Verbesserung des Wärmetransports ein Adapter konzipiert und untersucht.

Basierend auf den Ergebnissen werden erste Testmuster der solarthermischen Jalousie gefertigt.

1. Concept of solar thermal venetian blinds

Building envelopes have a great potential as area for installation of solar thermal collectors. By integrating solar thermal collectors into the building envelope a cost reduction of 40% can be achieved in comparison to collectors attached to the façade after the initial construction or retrofitting (Cappel et al. 2015; Maurer et al. submitted). However many façades in modern architecture use large glazed areas that offer little room for installing opaque building-integrated solar thermal (BIST) collectors. In double-skin façades as well as in closed-cavity façades (CCF) blinds are often installed in the cavity between outer and inner glazing. This can lead to a significant overheating of cavity and glazing (Gratia, Herde 2007). For the case of room ventilation via the cavity this also leads to a supply of hot air which especially in summer is not desired.

The idea of solar thermal venetian blinds (STVB) uses these blinds in the glazing cavity as collectors to supply renewable heat while allowing full movement of the blinds (cf. architectural model in Figure 1). Instead of reflecting the solar irradiation in the glazing areas and encapsulating the interior, transparent façade areas can thus actively lower the primary energy demand while keeping the same construction and benefits of the façade system. As an additional advantage it is investigated whether the overheating of the glazing cavity and interior glazing can be lowered. This would lead to higher thermal comfort and a lower cooling demand.

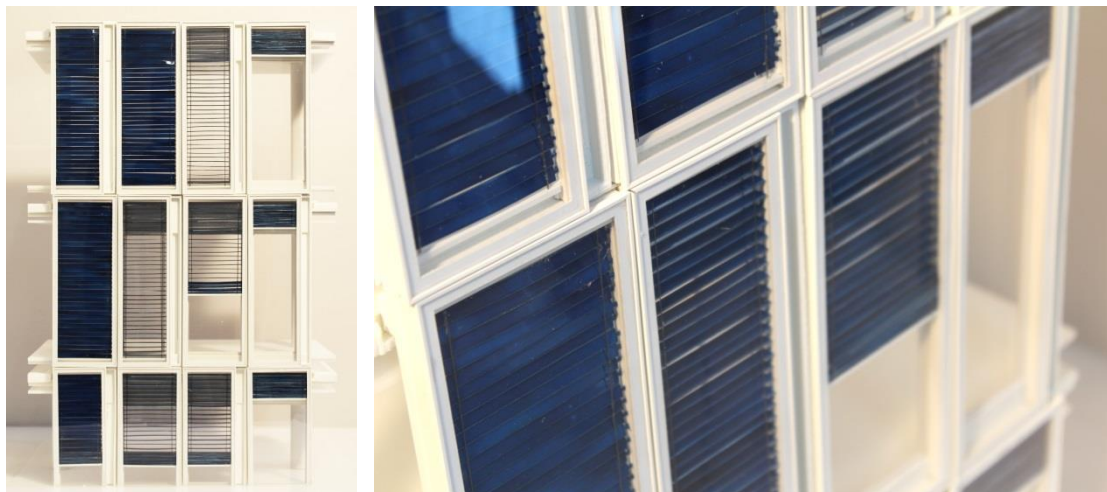

Figure 1: Architectural model of the solar thermal venetian blind as presented at the trade fair BAU 2017 in Munich.

In the project ArKol the use of heat-pipes of different geometries as part of the slats or slat itself in combination with a switchable thermal coupling between heat-pipe and header tube to realize the necessary heat transfer is investigated (cf. Figure 2). The

major challenges for the development of the solar thermal venetian blind is the operating angle needed for commercial solar heat-pipes (Morawietz et al. submitted) and the switchable thermal coupling between heat-pipe and header tube. First results of the development of said switchable thermal coupling are presented in this contribution.

1.1. Working principle of a solar thermal venetian blind

A typical façade element with a solar thermal venetian blind consists of an outer single glazing and an inner double or triple glazing. The STVB is mounted in between the glass units as shown in Figure 2. The slats function as absorber and can be coated depending on the application case, e.g. spectrally selective for high yields or diffusely reflecting for low g -values. The heat is transferred towards the side of the façade element via heat-pipes which are attached to the slats. At the side of the façade element the heat is transferred by the switchable thermal coupling to the vertically aligned header tube and the fluid in it. To increase the heat transfer between heat-pipe and header tube an adapter around the heat-pipe condenser with a larger contact area to the header tube can be used. The switchable thermal coupling, when it is closed, allows the heat transfer from slat via heat-pipe to the fluid circulation system of the technical building services. When the coupling is opened, i.e. heat-pipe and header tube are not in contact, the slats can be retracted, lowered and tilted. By employing heat-pipes, switchable thermal coupling and a single header tube each façade element only needs two hydraulic connections. An intelligent, user-adaptive control strategy for the blind can be used to control thermal comfort, solar thermal yield, glare protection and daylight supply in an optimized way.

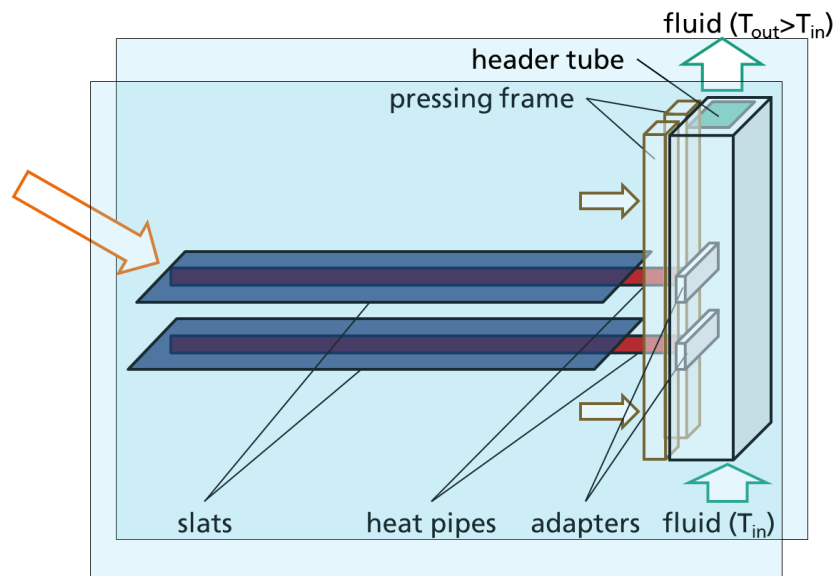

Figure 2: Working principle of a solar thermal venetian blind.

2. Methodology for development and evaluation

The solar thermal venetian blind has to function as building-integrated solar thermal collector and solar control system at the same time. Design parameters for the complete solar thermal venetian blind and for the switchable thermal coupling were investigated to analyze the technical design possibility. The latter are presented here. The evaluation of the switchable thermal coupling is bound to the evaluation criteria for the complete solar thermal venetian blind and is deduced from its requirements.

An overview of design parameters and general evaluation criteria for BIST collectors were published by (Cappel et al. 2015; Maurer et al. 2015). (Kuhn 2017) presented a design parameter space for solar control systems and different evaluation criteria that can be applied. This design parameter space was established in a way, that all design parameters are linear independent and represent all design possibilities. The choice and weighting of the evaluation criteria cannot be chosen independent of the application case (e.g. building type and usage). The design parameter and evaluation criteria for the switchable thermal coupling presented below have to be seen as preliminary at this state of the investigation of solar thermal venetian blinds.

2.1. Design parameter of the switchable thermal coupling

The design parameters are investigated for the subgroup of solar thermal venetian blinds with the following properties:

- With cylindrical heat-pipes attached to the slats for heat transfer
- With a switchable thermal coupling, that allows continuously adjustable retracting and tilting of the slats
- Positioning of the blind in the cavity between an outer and inner glazing

The switchable thermal coupling necessitates a mechanism to open and close the contact between heat-pipe (or adapter) and header tube. Using an adapter that encloses the heat-pipe condenser can be useful for the investigated variant with cylindrical heat-pipes. Here the adapter could lower the thermal resistance by increasing the contact area in comparison to the small contact area between the curved surface of the cylindrical heat-pipe and the planar surface of the header tube. The shape of the adapter is subject to the boundary condition of the needed condenser length and the direction of pressing. The design parameters of the switchable thermal coupling in Figure 3 were divided into the components mechanism and adapter.

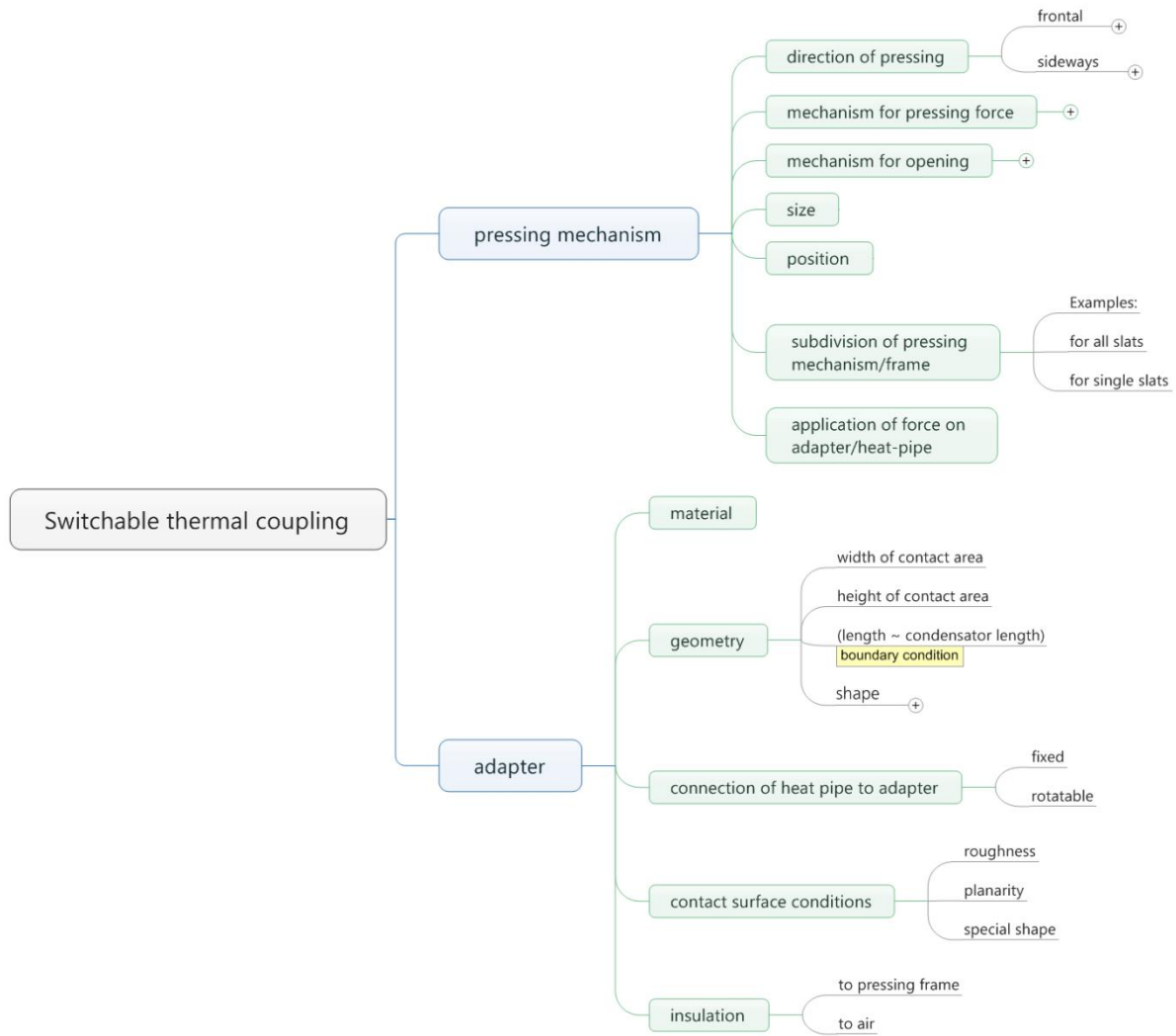

Figure 3: Design parameter of the switchable thermal coupling.

2.2. Evaluation methodology

Requirements for solar thermal venetian blinds

Besides the technical functionality, the development and design of solar thermal venetian blinds is subject to architectonic and aesthetic boundary conditions that are crucial for its acceptance and market success. The BIST-criteria *functionality*, *aesthetics*, *ecology*, *economy* and *feasibility* (Cappel et al. 2015) are applied during the development of the solar thermal venetian blind. Furthermore the evaluation criteria for solar control systems (Kuhn 2017) have to be applied as well. The exact definition and especially weighting of the different evaluation criteria depends on the application case. The *functionality* of the STVB can for example be evaluated with regards to supply of solar heat, thermal comfort and glare protection. The *ecology* can for example be analyzed and evaluated considering primary energy savings in comparison to a reference case without solar thermal activation or evaluation

methods such as Life Cycle Assessment. The evaluation of *economy* can be done with the criterion of Life Cycle Costing in comparison to reference cases. The evaluation of *aesthetics* could for example be done with the degree of integration or for façades with a large fraction of glazed area with the criterion of having a small opaque area of the STVB including frame. The *feasibility* of the STVB can for example be judged with regard to legal regulations.

Evaluation criteria of the switchable thermal coupling

The evaluation criteria in Figure 4 are used to compare different variants of the switchable thermal coupling and were derived from the general requirements for solar thermal venetian blinds. The evaluation criteria for solar control systems don't apply directly to the switchable thermal coupling because the mechanism should be located in the opaque, covered part of the façade element.



Figure 4: Overview of relevant evaluation criteria for the switchable thermal coupling.

The thermal resistance between heat-pipe and header should be as low as possible so that it is low in comparison to loss resistances to the surroundings. A short opening time is necessary to allow blind movement as quickly as possible after

requested by user interaction. As aesthetic criterion an opaque area of the façade element as small as possible was defined, i.e. the whole mechanism should be as narrow as possible.

3. Application to the development of the switchable thermal coupling

The mechanism of the switchable thermal coupling which is responsible for pressing and opening was designed with one movable pressing frame for all slats (cf. Figure 2). With this frame it is possible to use few actuators and ensure an equal force application on each adapter and slat. This approach can be used for both possible pressing directions (cf. Figure 5).

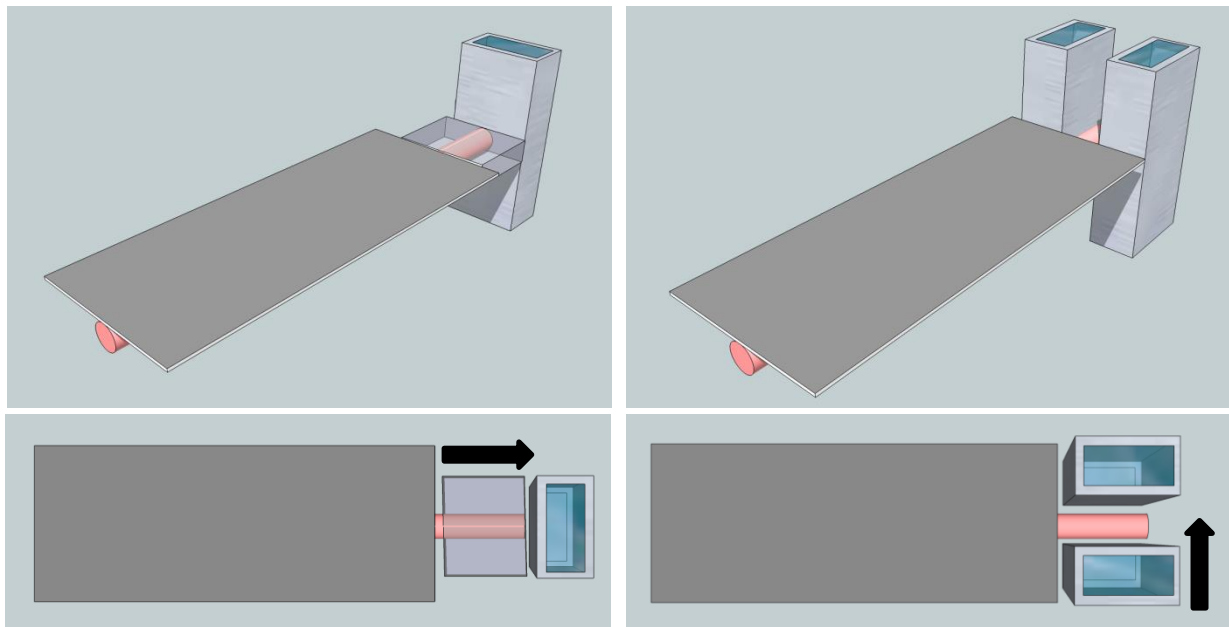

Figure 5: Two options for the pressing direction (black arrows): Frontal/axial (left side) and sideways pressing (right side). Adapter for frontal pressing is shown semitransparent for clarity, slat surface optionally with spectrally selective or other coatings.

3.1. Mechanism of the switchable thermal coupling

The development and evaluation of the mechanism of the switchable thermal coupling was investigated within the diploma thesis of one of the co-authors at Fraunhofer ISE (Abderrahman 2016). For the switchable thermal coupling five different mechanisms for pressing the adapter or heat-pipe onto the header tube and opening the contact were designed and investigated (listed in Table 1). These mechanisms differ in the actuator or mechanism for power transmission used to exert the force on the pressing frame.

The five mechanisms can be categorized with regard to their type of drive: variant 1: pneumatic, variant 2: electro-magnetic, variants 3-5: motor-driven. For variant 1 a long compressed air cushion is attached vertically to the pressing frame. To open the coupling the cushion is inflated and works against the springs. The springs are responsible to establish the contact between adapter/heat-pipe and header tube. Variant 2 works analogously with (self-latching) solenoids along the pressing frame. Variants 3 to 5 use an electric motor (e.g. stepper motor) with gear for pressing and opening. They differ in the mechanism used to transmit the force to the pressing frame. Variant 3 employs two vertically aligned camshafts. The cams directly move the pressing frame. Variants 4 and 5 use a slider crank mechanism or rack and pinion mechanism that are either attached at the top or bottom of the pressing frame and move it.

Table 1: Overview of investigated mechanisms.

	<i>Mechanism for pressing</i>	<i>Mechanism for opening</i>
1	Springs	Pneumatic with compressed air cushion
2	Springs	Solenoids
3	Camshaft (with electric motor)	
4	Slider-crank (with electric motor)	
5	Rack and pinion (with electric motor)	

Regarding the thermal coupling a large pressing force is desirable to minimize the thermal contact resistance. However larger and more expensive mechanisms are needed for higher pressing forces. At the same time the requirements on all mechanical components increase. During regular operation of the solar thermal venetian blind, the switchable thermal coupling is closed most of the time, i.e. in the pressed state. The coupling only has to open for the movement of the slats. Therefore the mechanism for pressing should need little or no energy to achieve a minimal auxiliary energy demand. For this reason springs (variants 1 and 2) or motor drives with self-locking power transmission (variants 3 – 5, e.g. in combination with a worm gear) were investigated. The long-term reliability poses a large challenge to the mechanisms especially for typical life times of façade elements of 20-30 years. At the same time the mechanisms should need little to no maintenance. For variants 3 – 5 the motors and gears should be free of abrasion and lubricant to keep the glazing cavity clean. Worm gears with their high gear ratio seem less favorable with regards to short opening times compared to solenoids. The noise level during operation has not been investigated yet. To minimize the opaque area small mechanisms are favorable. This is easier to achieve for less strong mechanisms. Also the positioning of the mechanism influences the opaque area. The costs of the components, operation and maintenance were estimated. In Table 2 the comparison of the investigated mechanisms is shown and judged on a scale of 1 to a maximum of 10.

The two most promising mechanisms, “2 – solenoid and springs” and “3 – camshaft (with electric motor)”, are being manufactured as test samples to show feasibility and gain more insights on long-term stability of components and mechanisms.

3.2. Optimization of the adapter

Different adapters were designed for both pressing directions to improve the thermal heat transfer between heat-pipe condensator and header tube (cf. Figure 5). This mainly works by having a larger contact area between adapter and header tube compared to a direct contact between heat-pipe and header tube. Both adapters have to allow tilting of the slats. Moreover the adapters have to be designed so that the pressing force transmitted by the pressing frame acts on the adapter under all slat tilt angles. The adapters should completely enclose the necessary length of the heat-pipe condensator. This length was estimated to roughly 100 *mm* for a heat-pipe and condensator of 10 *mm* diameter.

For the frontal pressing direction a wide adapter that is fixed permanently to the heat-pipe is possible as shown in Figure 5 and Figure 6. For the sideways pressing an adapter was designed which sits loosely on the heat-pipe and can be rotated around it when the slats are tilted. This way the contact area remains parallel to the header tube (cf. Figure 6). The advantage of frontal pressing is the permanent and strong connection, e.g. by heat shrinking, between heat-pipe and adapter. This ensures a small thermal contact resistance. A disadvantage is that the distance to the header tube gets longer along the condensator, i.e. the path for heat transfer through the adapter can be long. Sideways pressing has the advantage of a short distance between the whole heat-pipe condensator and the header tube. On the other hand two pressed non-permanent thermal contacts are present. These are the contact between heat-pipe and adapter and between adapter and header tube.

The key evaluation criterion for the decision on pressing direction and optimization of the adapters is the total thermal resistance between heat-pipe condensator and header tube which needs to be minimized. It constitutes of the two thermal contact resistances condensator-adapter and adapter-header tube and of the bulk thermal resistance of the adapter between the two contact surfaces.

Table 2: Evaluation of the different mechanism of the switchable thermal coupling.

design	thermal resistance		auxiliary energy demand		distribution of force		reliability		opening time		opaque area		cost		sum
1 - pneumatic with compressed air cushion and springs	High forces possible with additional stress on components	7	Supply of compressed air and actuator for valve(s)	5	Equally distributed pressure for opening and in different points for pressing depending on number of springs	7	Potential leakage problems due to seals and gaskets failure (especially for high temperatures and long life time)	5	Quick with constant supply of compressed air	7	Big opaque area due to air cushion	5	Expensive components, maintenance and operation of compressed air system	4	40
2 - solenoid and springs	High forces require large and expensive solenoids	6	Activation of solenoid for opening movement	8	Pressure located in different points depending on number of springs and solenoids	6	Potential breaking of springs, wear of solenoid plunger	8	Fast	8	Small opaque area due to small components (solenoid and springs)	7	Fewer and affordable components	8	51
3 - camshaft	High forces can be applied with suitable motor	8	Electric energy for electric motor	6	Pressure located in different points along pressing frame depending on number of cams	6	Wear of motor, gears and cam on pressing frame can cause failure	7	Slower, depending on gear ratio	5	Medium opaque area due to camshaft	6	Affordable mechanical components but costly motor	6	44
4 - slider crank	High forces can be applied with suitable motor	8	Electric energy for electric motor	6	Pressure located in few points at top and/or bottom of pressing frame	4	Wear of motor, gears and slider-crank can cause failure	6	Slower, depending on gear ratio	5	Medium opaque area due to slider-crank mechanism	6	Affordable mechanical components but costly motor	6	41
5- rack and pinion	High forces can be applied with suitable motor	8	Electric energy for electric motor	6	Pressure located in few points at top and/or bottom of pressing frame	4	Wear of motor and gears can cause failure	7	Slower, depending on gear ratio	5	Small opaque area due to small components (gears)	7	Affordable mechanical components but costly motor	6	43

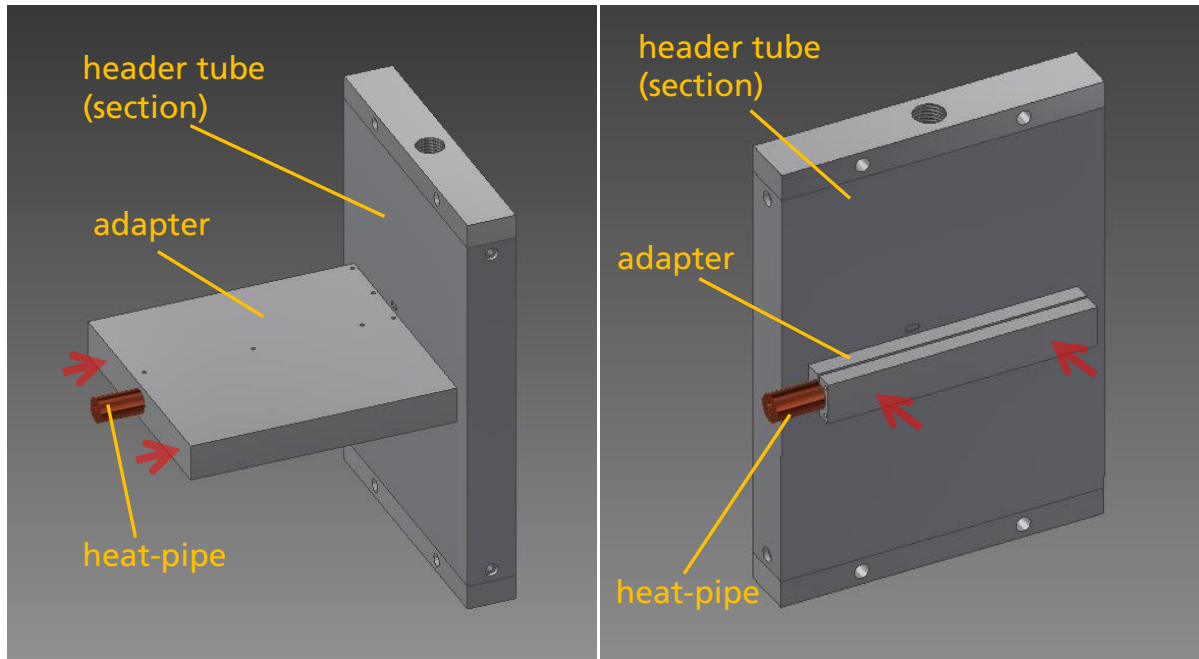

Figure 6: Adapter concepts for frontal (left) and sideways pressing direction (right).

The calculation of the thermal contact resistance can be done with various models (compare (Bejan, Kraus 2003)). Main parameters are contact pressure and surface conditions, especially roughness. Important relevant material properties are bulk thermal conductivity and micro hardness of the contact surfaces. The thermal contact resistance decreases roughly inversely proportional with increasing pressing force ($R_c \sim \frac{1}{F}$) and decreases with decreasing roughness (cf. Figure 7). Thus a small roughness and high pressing force is desirable. Additionally both contact areas have to have very high planarity to ensure contact exists over the whole contact area. Two contacting aluminum surfaces with an area $A = 10\text{cm} * 1.5\text{cm}$, RMS roughness $\sigma = 1.6\mu\text{m}$ and pressing force $F = 5 - 10\text{N}$ experience a thermal contact resistance in the order of $R_c \approx 0.2 \frac{\text{K}}{\text{W}}$. Experiments to investigate the heat transfer between heat-pipe condensator and header tube are performed currently. The surface conditions (roughness and planarity) of the contact areas have to be optimized regarding manufacturing costs and thermal contact resistance.

The bulk thermal resistance of the adapter R_{adapt} was investigated with finite element method in COMSOL Multiphysics with the aim of comparing pressing directions and subsequently optimizing adapter geometry and choosing adapter material. The height H of the adapter was set to 15mm for both pressing directions to ensure a small packing height of the retracted blind. The length L of the adapter along the heat-pipe was set to 100mm according to the condensator length. The cross-section of the adapter for sideways pressing is square and thus the width $W = H$. The width W of the adapter for frontal pressing was varied and investigated as shown in Figure 8.

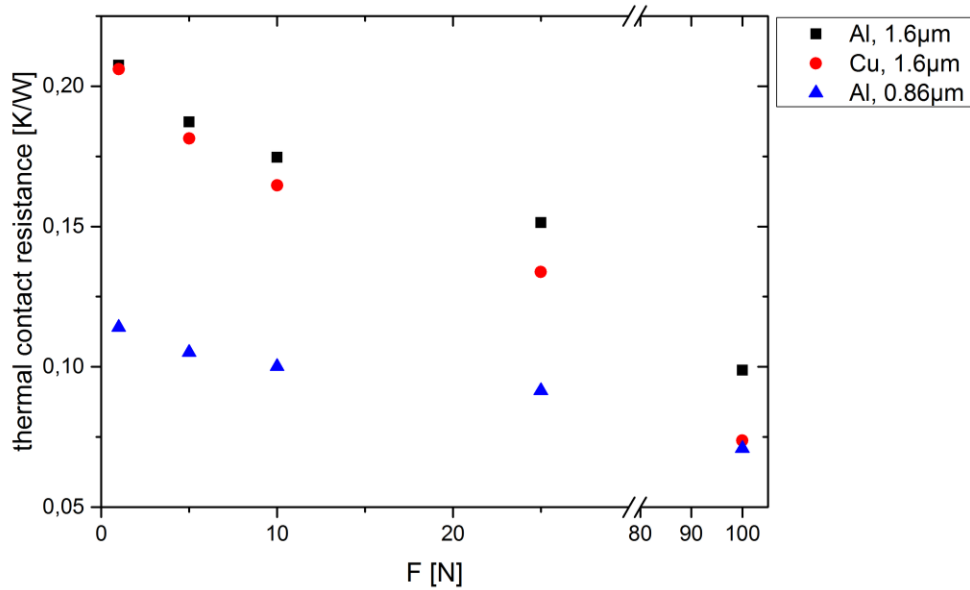

Figure 7: Thermal contact resistance R_c as a function of pressing force for different materials (aluminum, copper) and roughness, calculated according to (Bahrami et al. 2004).

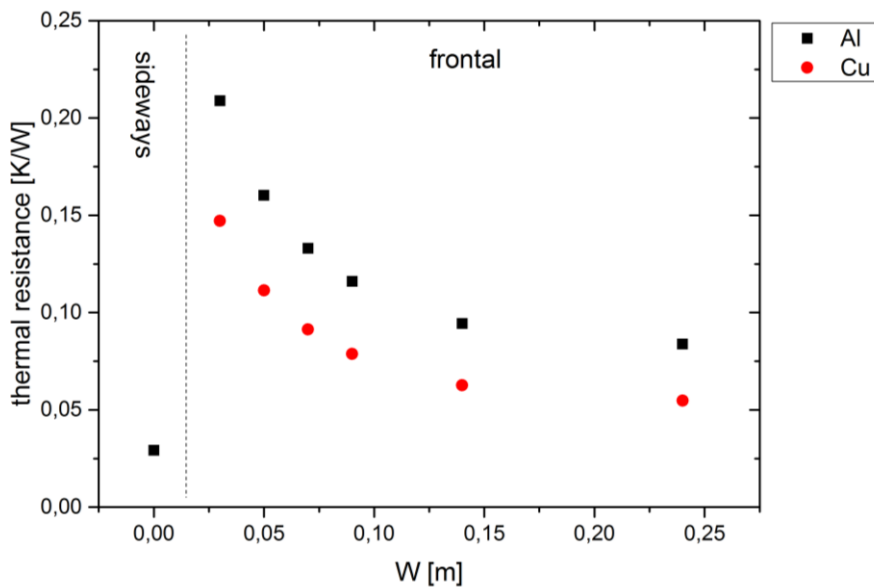

Figure 8: Thermal resistance R_{adapt} of the adapter as a function of adapter width W for different materials and pressing direction. Sideways pressing is shown at $W = 0$ for comparison.

Comparing the total thermal resistances of sideways pressing $R_{side} \approx 2R_c + R_{adapt} \approx 2 * 0,2 \frac{K}{W} + 0,03 \frac{K}{W} = 0,43 \frac{K}{W}$ and of frontal pressing (with $W = 7 \text{ cm}$) $R_{front} \approx R_c + R_{adapt} \approx 0,2 \frac{K}{W} + 0,13 \frac{K}{W} = 0,33 \frac{K}{W}$ shows the significance of the thermal contact resistance which dominates for sideways pressing. This comparison is currently being investigated experimentally. For the first test sample of the solar thermal venetian blind the frontal pressing direction was chosen due to the expected lower total thermal resistance.

The comparison of adapter materials copper and aluminum in Figure 8 shows as expected a better heat transfer for copper. Comparing the weight of adapters for comparable thermal resistances however shows that an aluminum adapter is roughly 30 – 40% lighter (cf. Table 3). Because the adapter adds to the slat weight a larger but lighter adapter out of aluminum has to be preferred over a heavier copper adapter if the thermal resistance is comparable. As aluminum is the main material used in the planned STVB façade elements, it is also preferable with regards to material compatibility and costs.

Table 3: Thermal resistance R_{adapt} and weight for different adapter widths W and materials.

material	W [m]	R_{adapt} [K/W]	weight [g]
Cu	0.03	0.15	343
Cu	0.05	0.11	618
Cu	0.09	0.08	472
Al	0.03	0.2	104
Al	0.05	0.16	187
Al	0.09	0.12	354

Up to now heat losses to the surrounding weren't considered in detail. Insulating the adapter against the pressing frame and surrounding air makes sense but is limited due to space limitation.

For the first test sample the frontal pressing direction with solenoids and springs was chosen as most promising case. As shown in Figure 9 the heat-pipe is attached to the bottom of the blind diagonally to ensure a tilt angle for the heat-pipe operation. The adapter was manufactured out of aluminum with a width of 70 mm not taking into account the extensions for pressing. At the same time the second variant of the pressing mechanism with camshaft is being developed in detail.

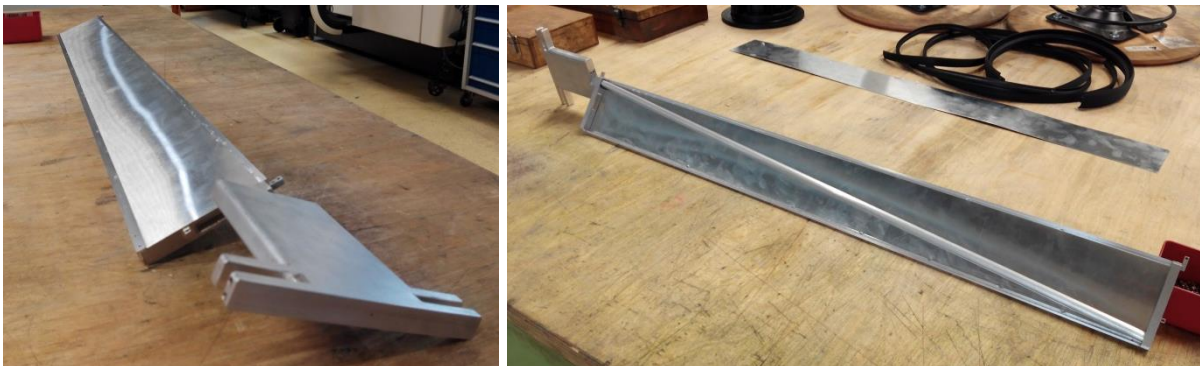

Figure 9: First produced slat of the test sample with adapter in the foreground (left) and bottom view of the slat with diagonally attached heat-pipe (right).

4. Conclusion and outlook

Switchable thermal couplings in combination with heat-pipes can offer an approach to make solar thermal venetian blinds technically feasible. The methodology of design parameters and evaluation criteria was applied to different variants of the mechanism of the switchable thermal coupling. The pressing direction and design of the adapter were investigated and evaluated with regard to their thermal resistance. Based on these findings the first test sample of the solar thermal venetian blind was developed and is being manufactured. As next steps the mechanisms will undergo long-term testing to study the reliability. Furthermore thermal and optical measurement on laboratory test samples of the solar thermal venetian blinds will be executed. Detailed theoretical models of the solar thermal venetian blind will be developed and used in building simulations to evaluate the potential of solar thermal venetian blinds in different application scenarios. The presented methodology using design parameters and evaluation criteria will be extended and applied to the whole solar thermal venetian blind.

Acknowledgements

The authors would like to thank the staff of the mechanical workshop of Fraunhofer ISE for technical support. This work was funded by the German Federal Ministry for Economic Affairs and Energy because of a decision by the German Bundestag.

References

- Abderrahman, Ikbel (2016): Design of innovative building-integrated systems. Diploma thesis. Université de Sousse, Tunisia. Ecole Nationale d'Ingénieurs de Sousse.
- Bahrami, M.; Yovanovich, M. M.; Culham, J. R. (2004): Thermal Joint Resistances of Conforming Rough Surfaces with Gas Filled Caps. In *Journal of Thermophysics and Heat Transfer* 18 (3), pp. 318–325. DOI: 10.2514/1.5480.
- Bejan, Adrian; Kraus, Allan D. (2003): Heat transfer handbook. Hoboken, NJ: Wiley. Available online at <http://www.loc.gov/catdir/description/wiley039/2002028857.html>.
- Cappel, Christoph; Streicher, Wolfgang; Hauer, Martin; Lichtblau, Florian; Szuder, Thomas; Kuhn, Tilmann E.; Maurer, Christoph (2015): "AktiFas" Fassadenintegrierte Solarthermie: Bestandsaufnahme und Entwicklung zukunftsfähiger Konzepte. Schlussbericht. Fraunhofer Institut für solare Energiesysteme ISE. Freiburg. Available online at <http://publica.fraunhofer.de/dokumente/N-349495.html>.
- Gratia, Elisabeth; Herde, André de (2007): The most efficient position of shading devices in a double-skin facade. In *Energy and Buildings* 39 (3), pp. 364–373. DOI: 10.1016/j.enbuild.2006.09.001.
- Kuhn, Tilmann E. (2017): State of the art of advanced solar control devices for buildings. In *Solar Energy*. DOI: 10.1016/j.solener.2016.12.044.

Maurer, Christoph; Cappel, Christoph; Kuhn, Tilmann E. (submitted): Progress in building-integrated solar thermal systems. In Elsevier (Ed.): Progress in Solar Energy. Solar Energy.

Maurer, Christoph; Cappel, Christoph; Kuhn, Tilmann E. (2015): Methodology and first results of an R&D road map for façade-integrated solar thermal systems. In *Energy Procedia* 70, pp. 704–708. DOI: 10.1016/j.egypro.2015.02.179.

Morawietz, Katharina; Hermann, Michael; Schaffeld, Georg (submitted): Wärmerohre für flexibel ausrichtbare solarthermische Kollektoren – Stand der Technik und neue Ansätze. In OTTI e.V. (Ed.). 27. Symposium Thermische Solarenergie. Bad Staffelstein, Germany, 10. -12. Mai.